

Lab 01



8051 Assembly Programming



The Goal of Lab 01

- Guide you to write your first 8051 assembly program
 - and perhaps your first assembly program
- Your work: write a program to compute

$$S = \sum_{i=0}^{N-1} A[i] * B[i]$$

- where $A[i]$, $B[i]$ are integer arrays (8-bit) in 8051's internal memory

Overview: the C8051F040 SoC

- a **system-on-a-chip** integrating the processor core, memory, peripheral devices, everything in a computer system

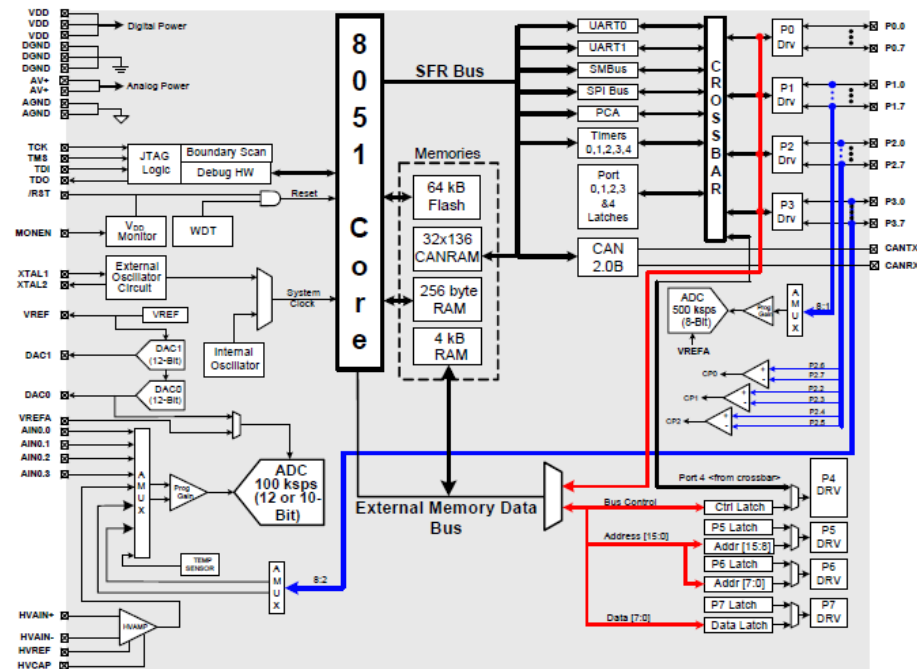

Fundamental: von Neumann
model in assembly level





The Von Neumann Model

$D = A + B * C;$
 $E = D + F;$
 $A = A - 1;$

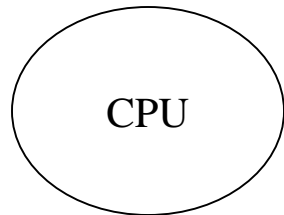

PC: program counter

memory

A 10

B 20

C 30

D 40

E 50

F 60

The Von Neumann Model

PC → $D = A + B * C;$
 $E = D + F;$
 $A = A - 1;$

PC: program counter

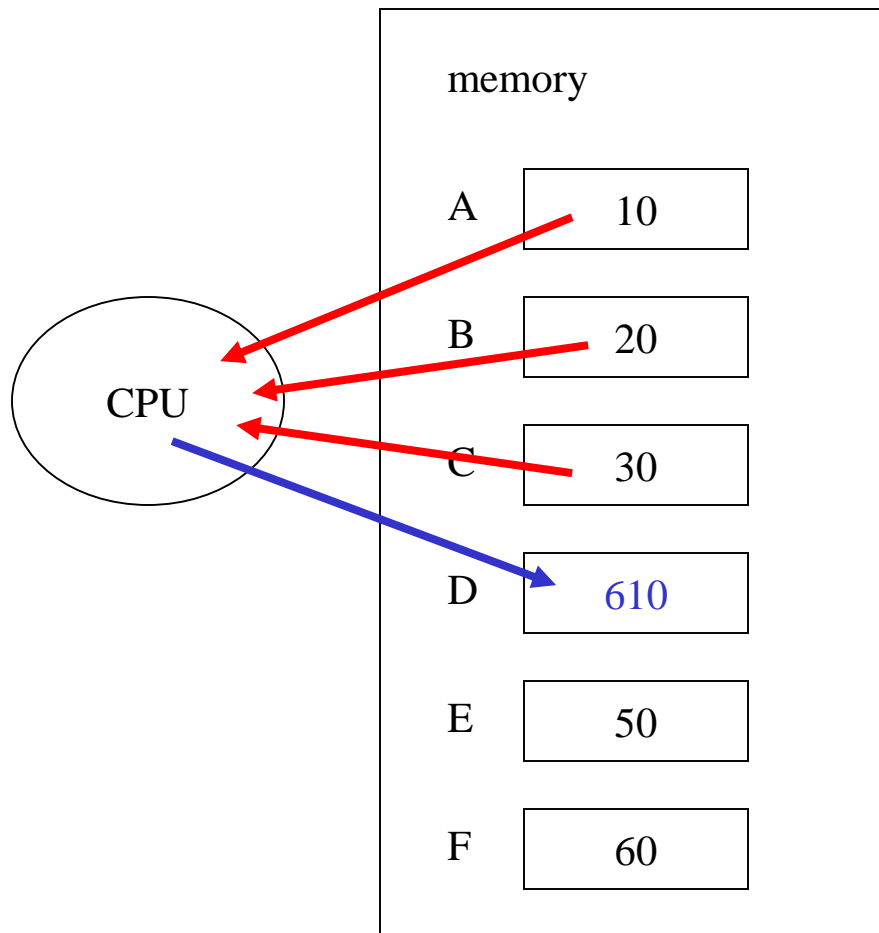

The Von Neumann Model

PC → $D = A + B * C;$
 $E = D + F;$
 $A = A - 1;$

PC: program counter

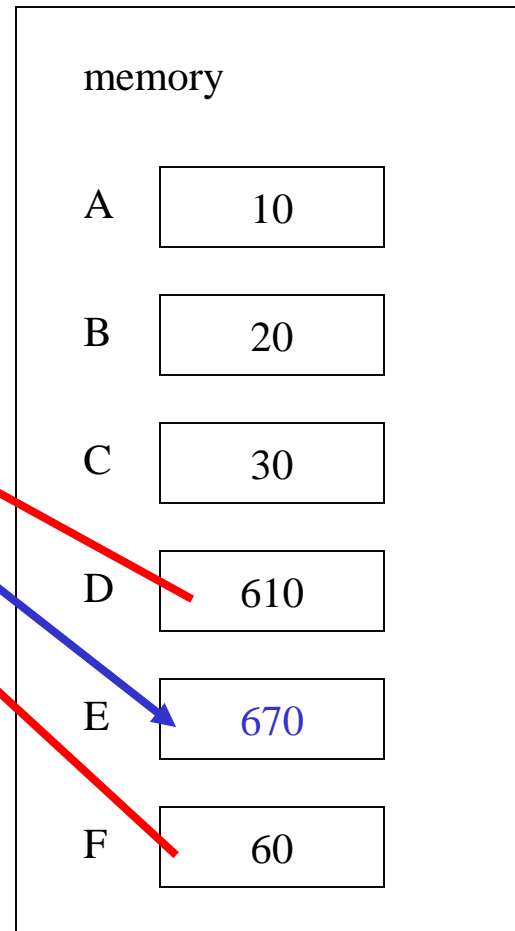
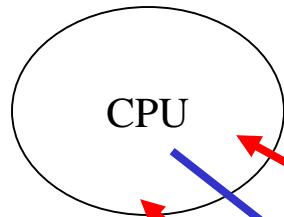

The Von Neumann Model

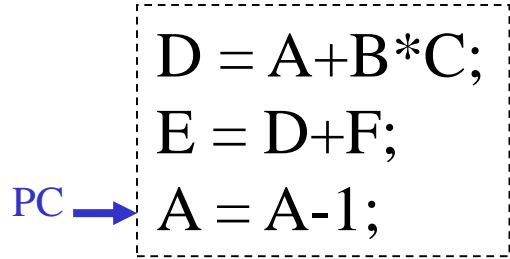

PC: program counter

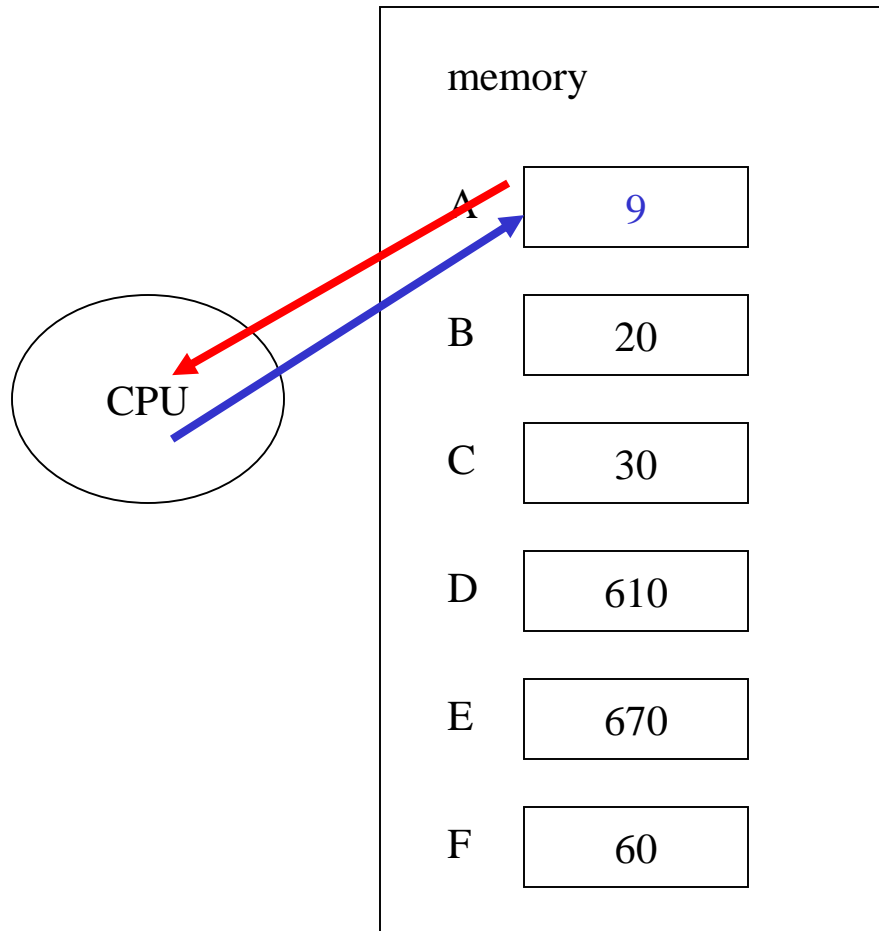



How a CPU works?

- follow the von Neumann model
 - step by step
 - one *instruction* per step
- but decompose operations into primitive and regular ones

```
D = A+B*C;  
E = D+F;  
A = A-1;
```

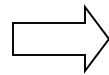

assembly program

```
load R1, A;      //R1 = mem[A];  
load R2, B;      //R2 = mem[B];  
load R3, C;      //R3 = mem[C];  
mult R4, R2, R3; //R4=R2*R3;  
add R5, R1, R4;  //R5=R1+R4;  
store D, R5;     //mem[D] = R5;  
load R6, F;      //R6 = mem[D];  
add R7, R5, R6;  //R7 = R5+R6;  
store E, R7;     //mem[E] = R7;  
sub R1, R1, 1;   //R1 = R1-1;  
store A, R1;     //mem[A] = R1;
```



Question

- Q: what's the major difference between assembly programming and high-level language programming?
- A: you have to imagine how hardware works!

How a CPU works?

- from hardware design perspective
- the data path:

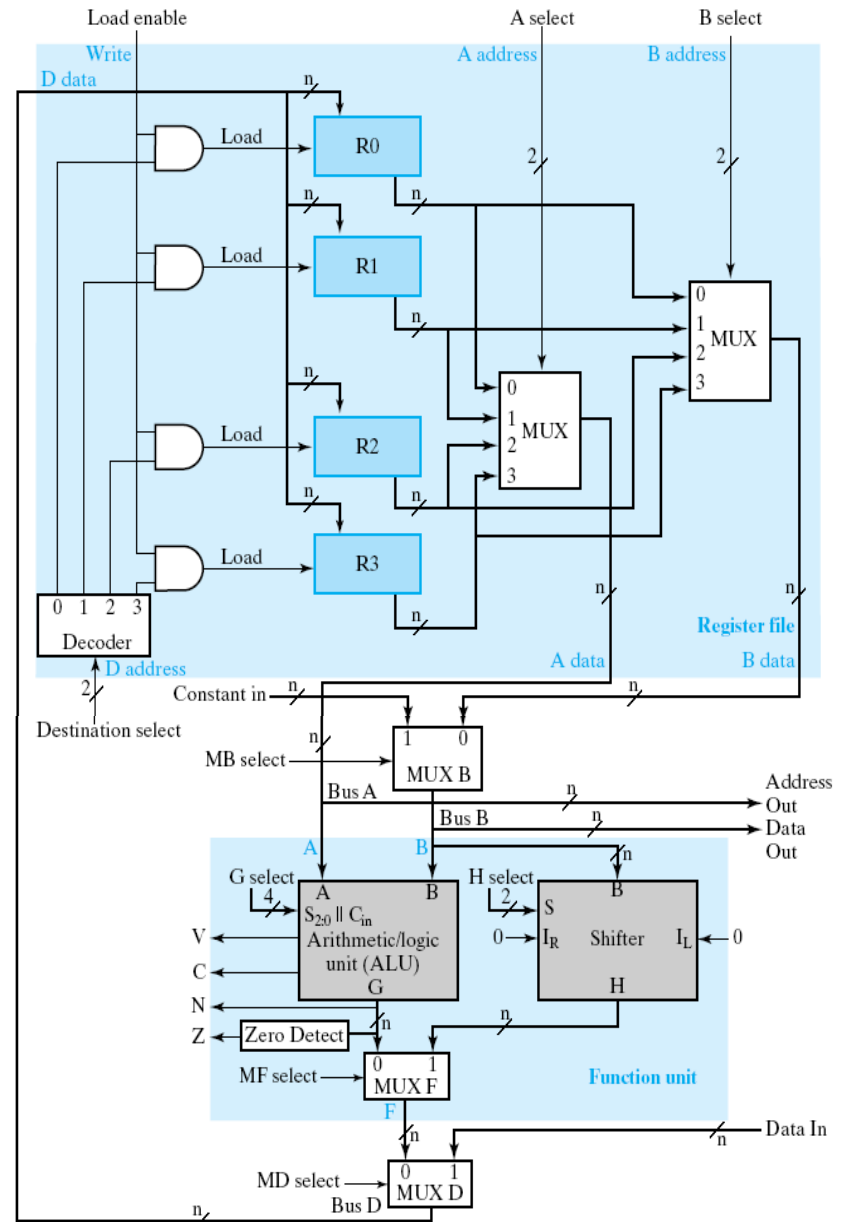

How a CPU works?

- registers to store *variables*

registers

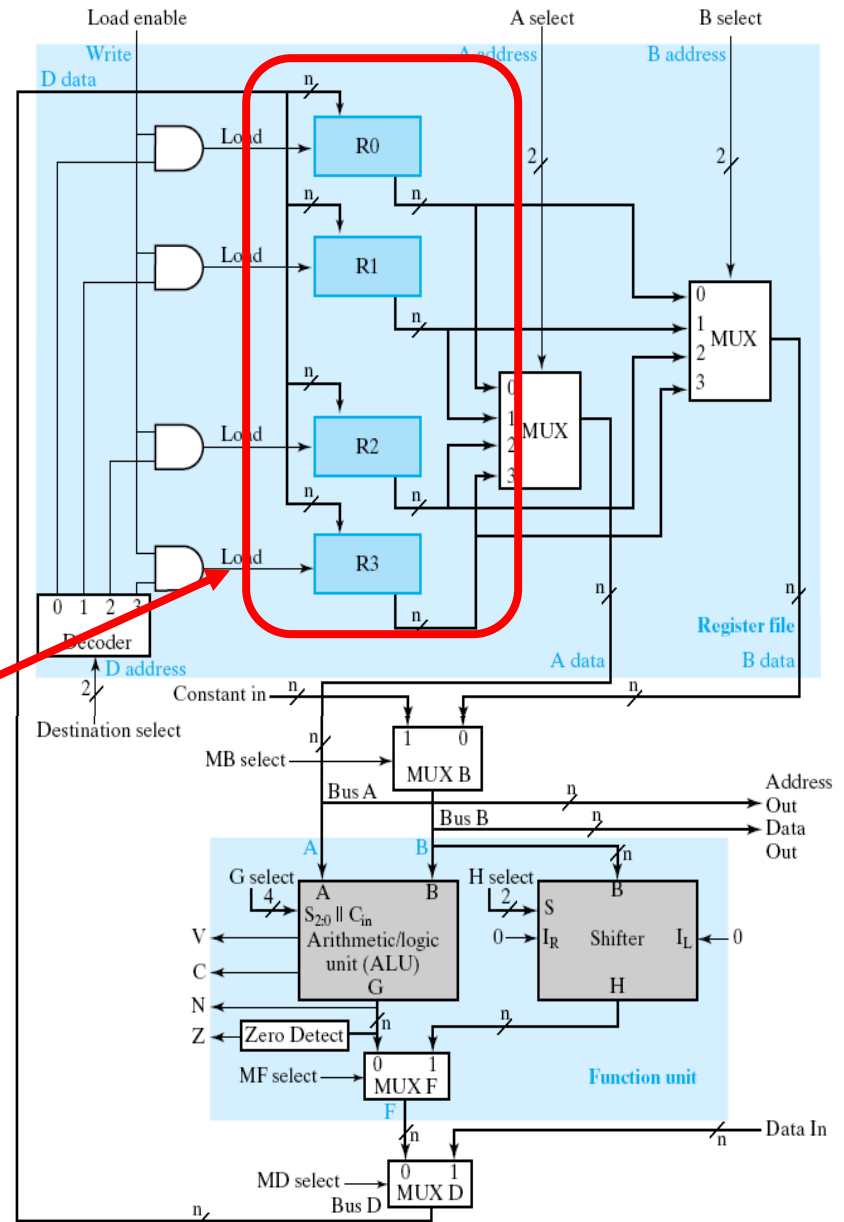

How a CPU works?

- function units to perform computation

function units

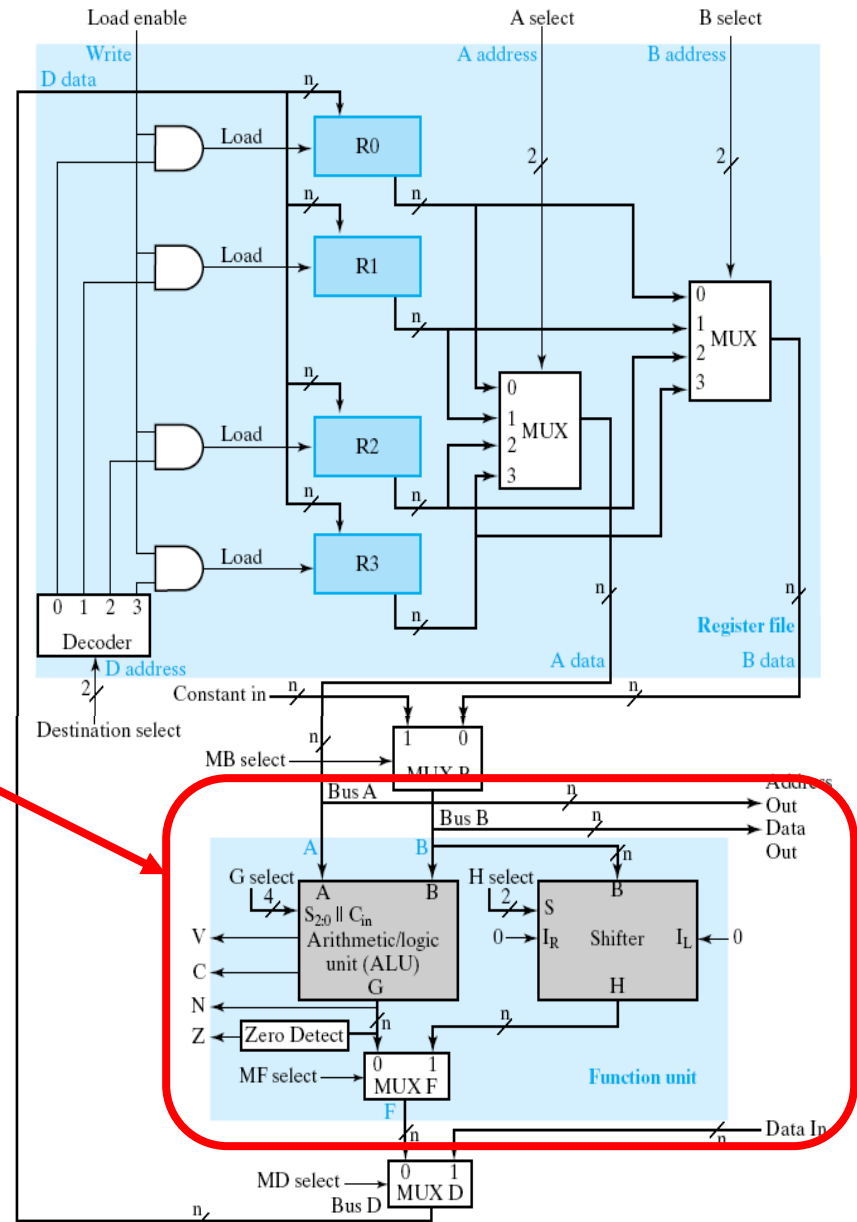

How a CPU works?

- still follows von Neumann model

$A = B + C;$

load R1, B; //R1 = mem[B];
 load R2, C; //R2 = mem[C];
 add R3, R1, R2; //R3 = R1+R2;
 store A, R3; //mem[A] = R3;

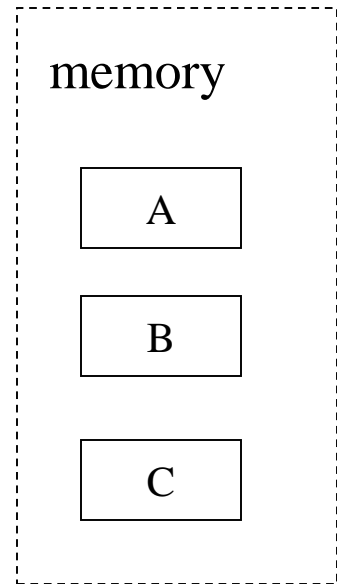
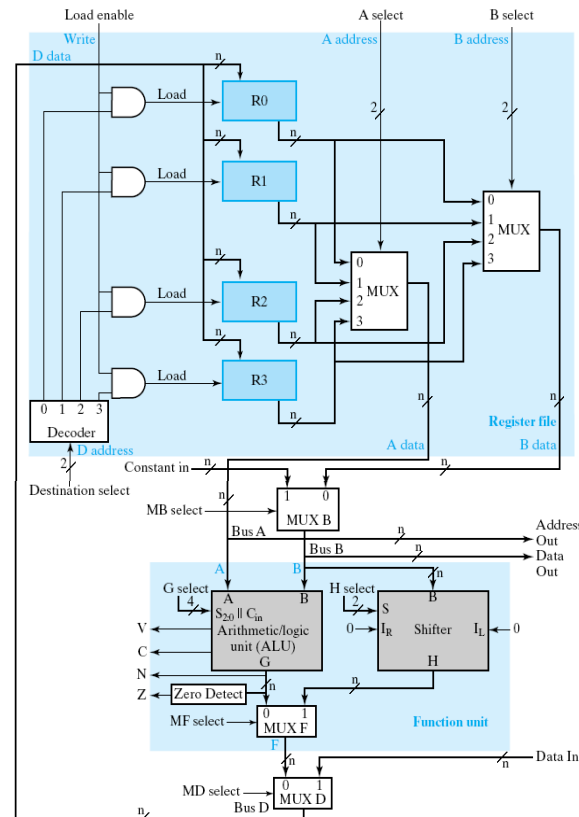

How a CPU works?

- still follows von Neumann model

$A = B + C;$

```

load R1, B; //R1 = mem[B];
load R2, C; //R2 = mem[C];
add R3, R1, R2; //R3 = R1+R2;
store A, R3; //mem[A] = R3;
    
```

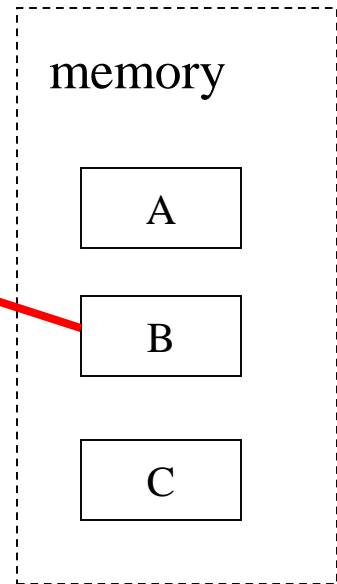
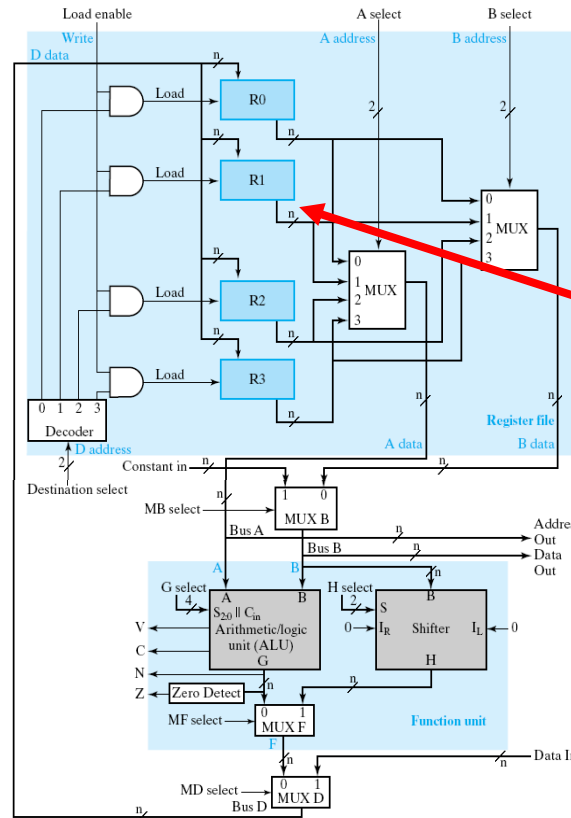

How a CPU works?

- still follows von Neumann model

$A = B + C;$

\rightarrow load R1, B; //R1 = mem[B];
 load R2, C; //R2 = mem[C];
 add R3, R1, R2; //R3 = R1+R2;
 store A, R3; //mem[A] = R3;

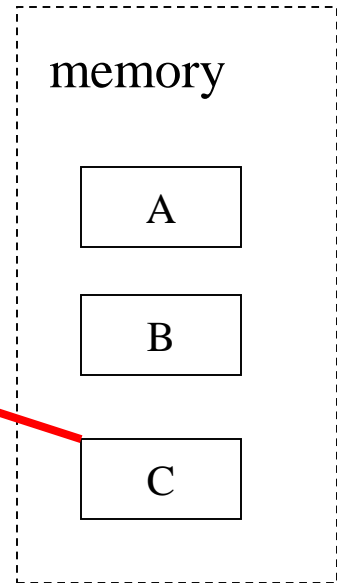
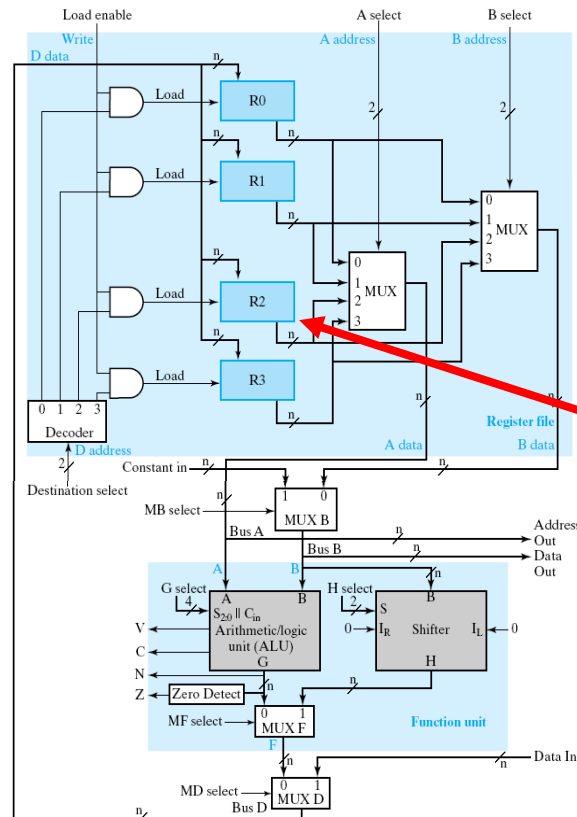

How a CPU works?

- still follows von Neumann model

$A = B + C;$

`load R1, B; //R1 = mem[B];`
`load R2, C; //R2 = mem[C];`
`add R3, R1, R2; //R3 = R1+R2;`
`store A, R3; //mem[A] = R3;`

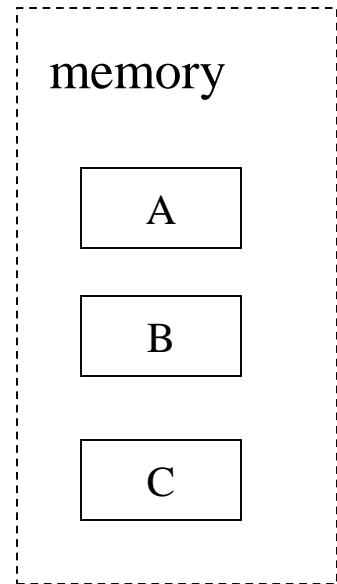
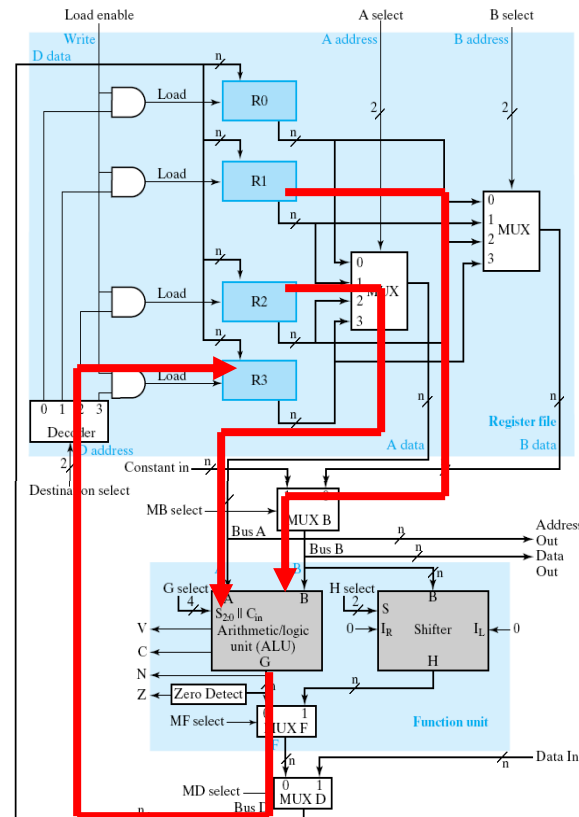

How a CPU works?

- still follows von Neumann model

$A = B + C;$

load R1, B; //R1 = mem[B];
 load R2, C; //R2 = mem[C];
 add R3, R1, R2; //R3 = R1+R2;
 store A, R3; //mem[A] = R3;

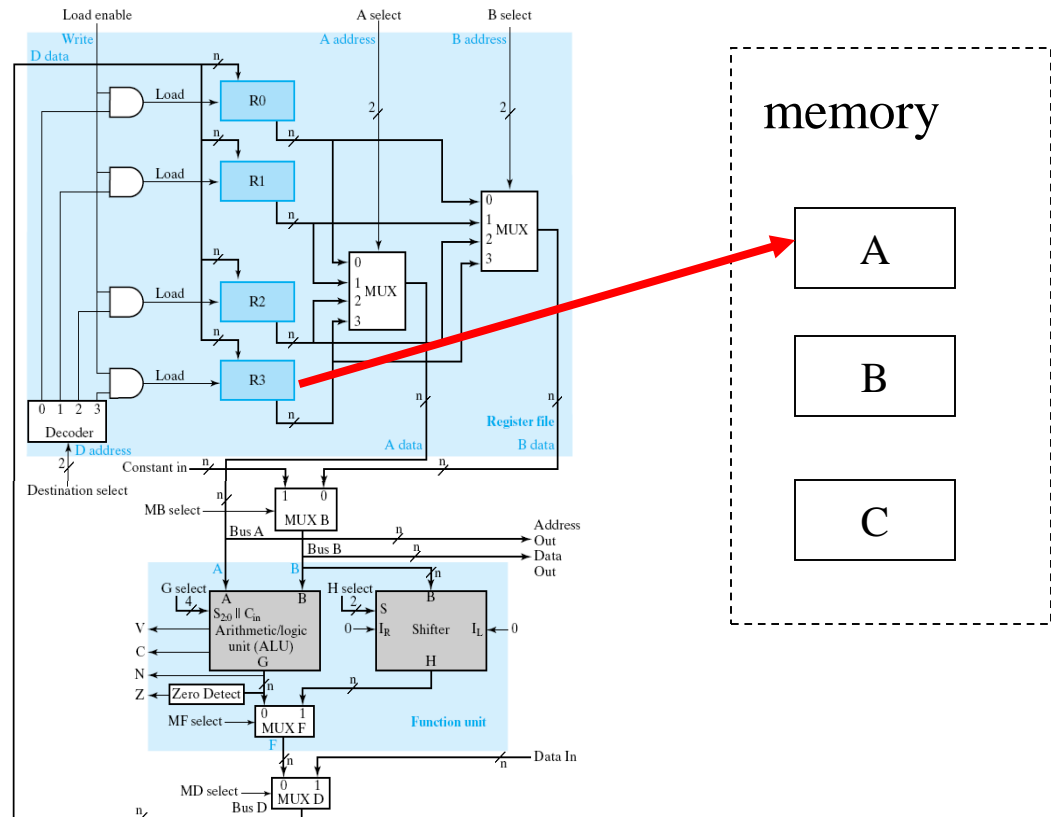



8051 Architecture Model

Imagination on 8051 architecture

- Imagine how data flow in the architecture!

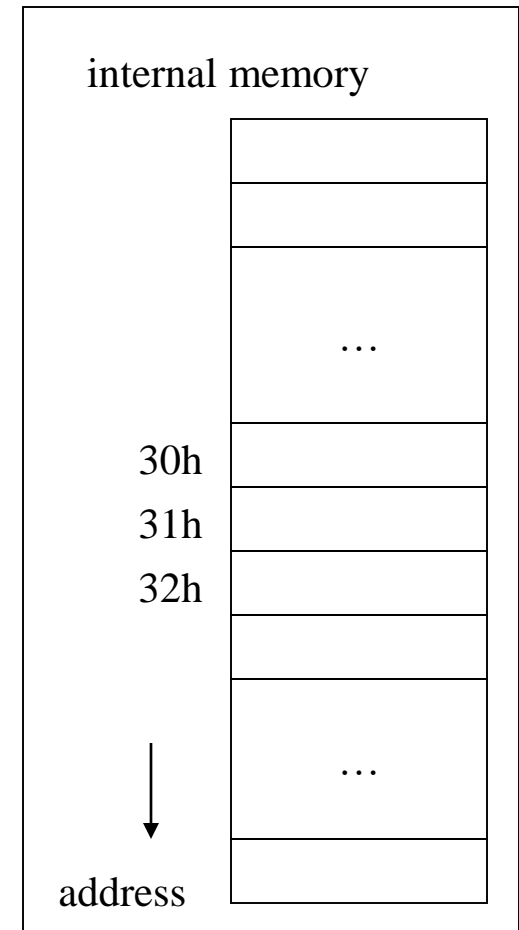
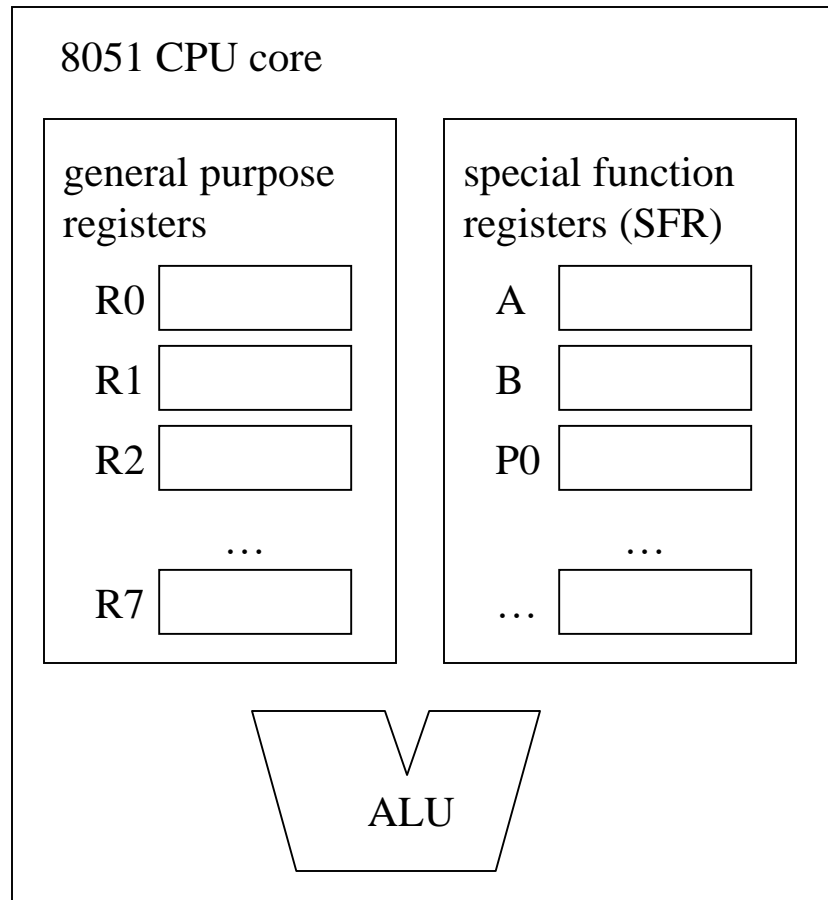

Imagination on 8051 architecture

- flow of an arithmetic instruction

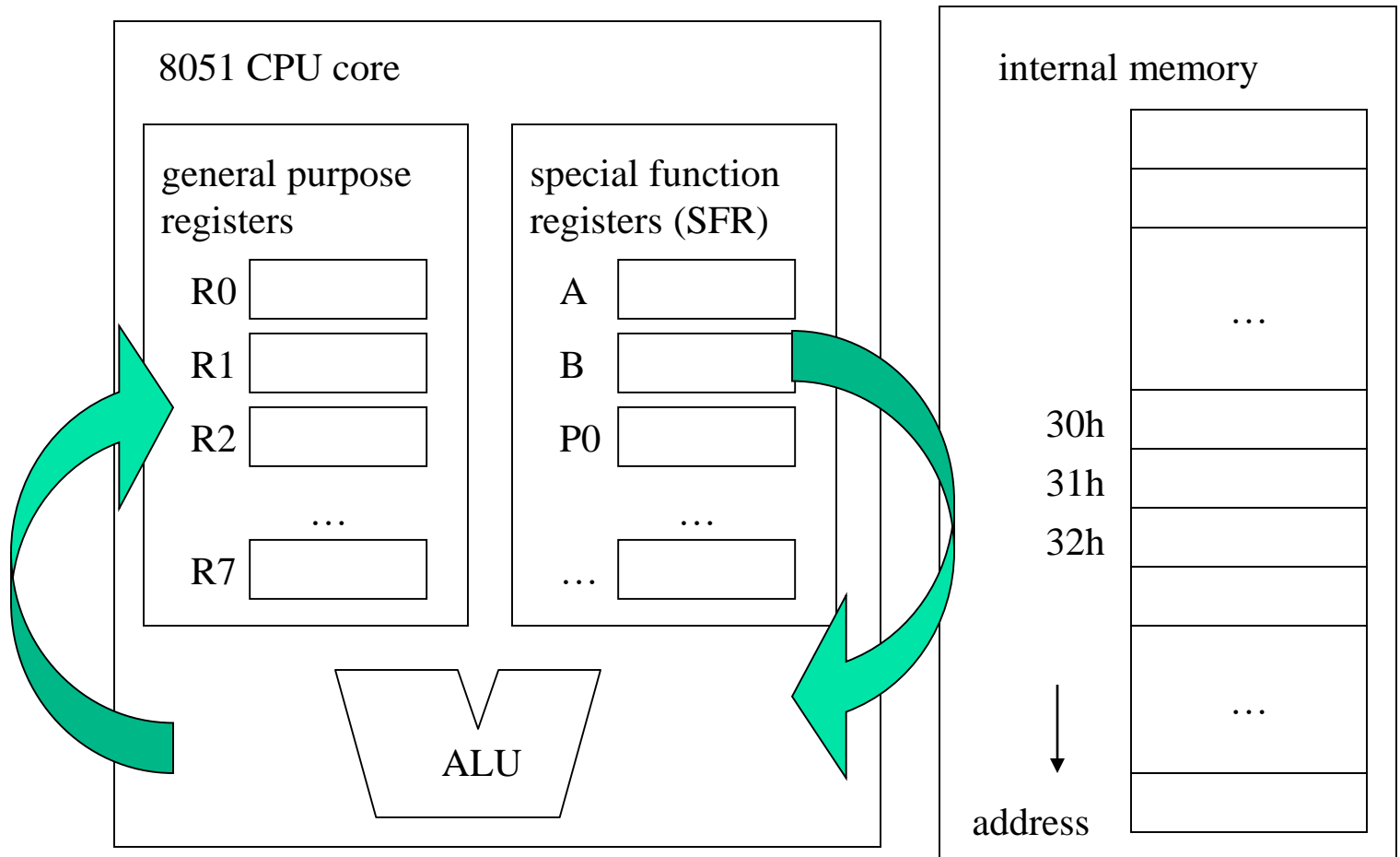

Imagination on 8051 architecture

- data movement between memory and registers
- the MOV instruction

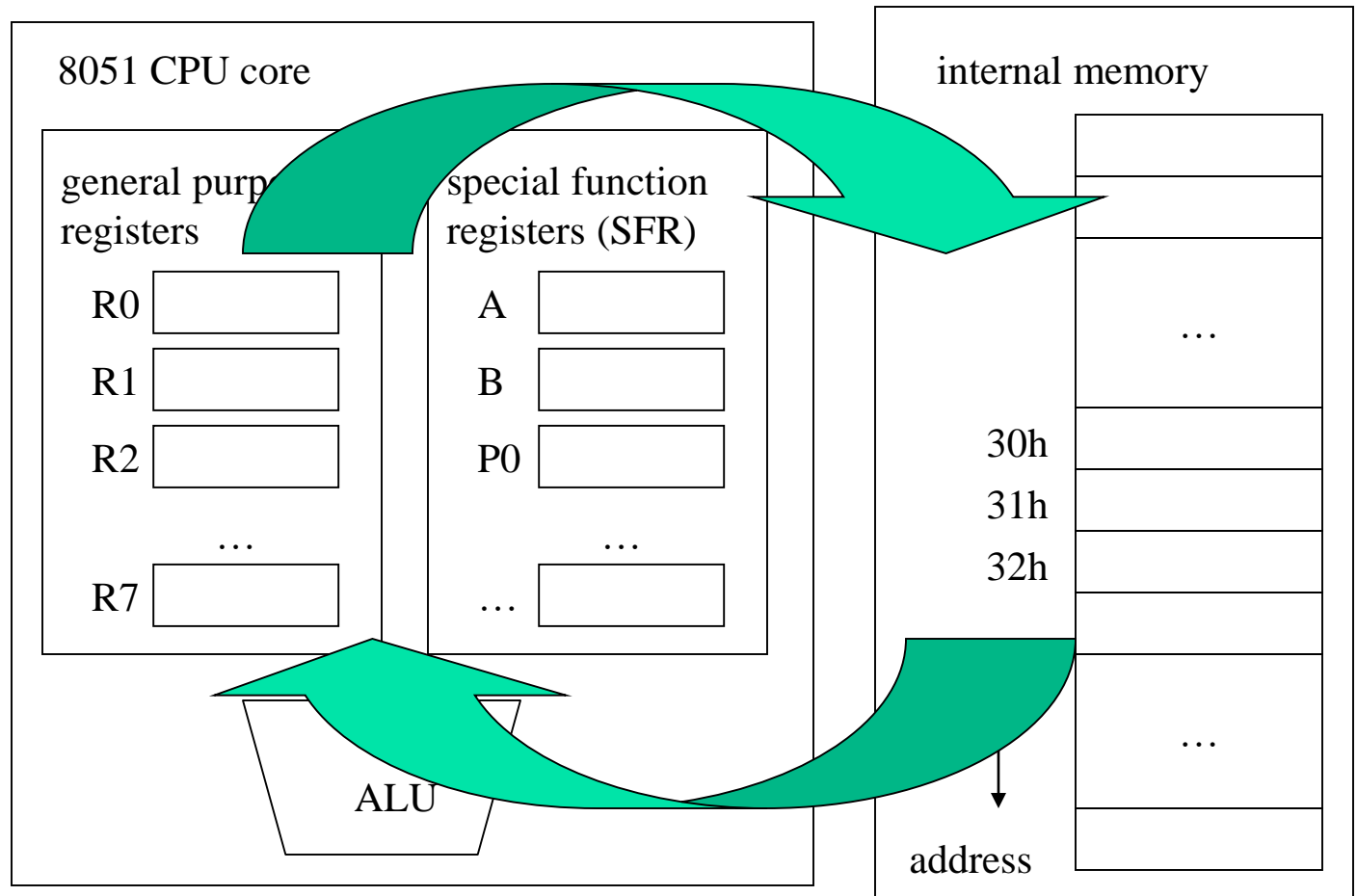

Imagination on 8051 architecture

- the MOV also for registers

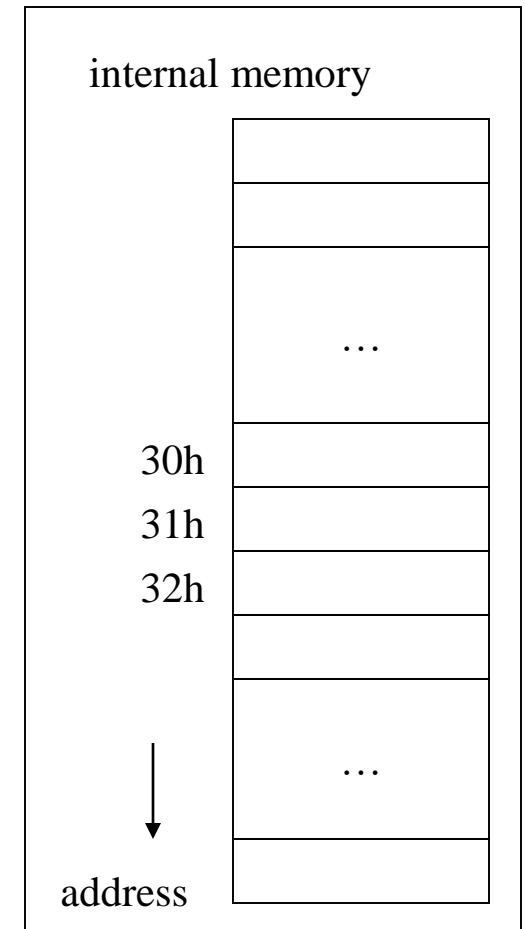
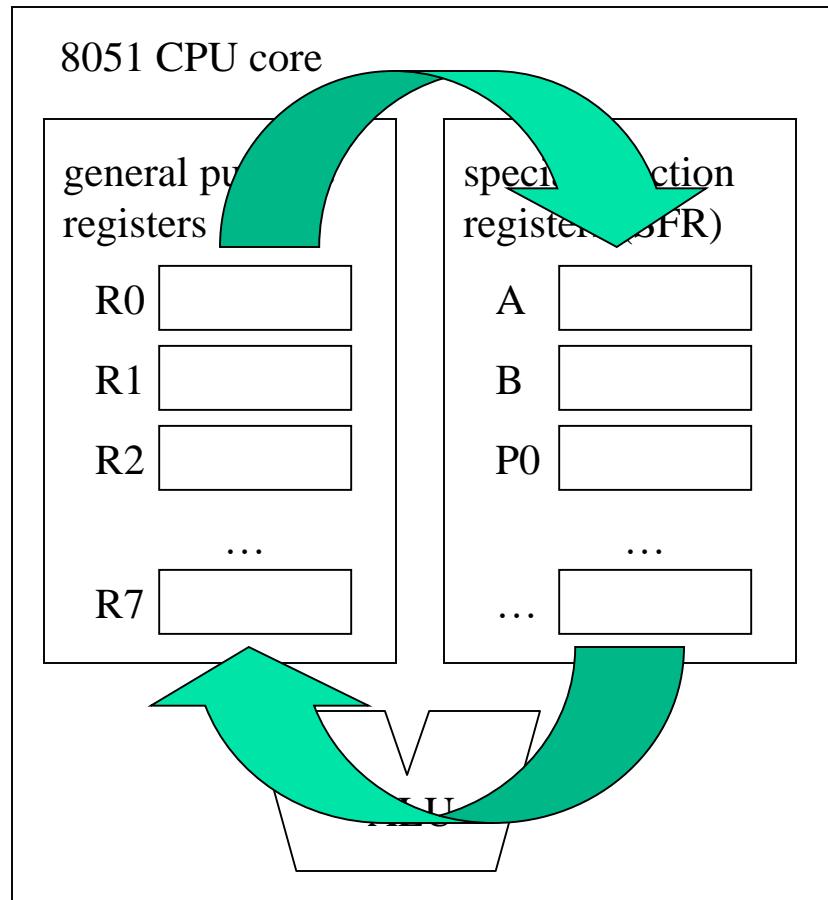

Imagination on 8051 architecture

- Feature: most of instructions have limited use on registers
- Example:
 - ADD uses ACC
 - MUL (multiply) uses A and B

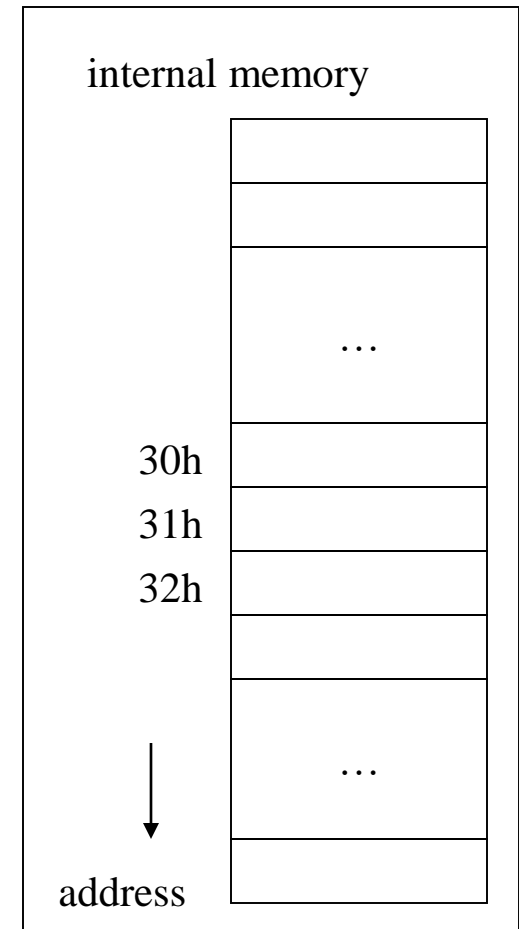
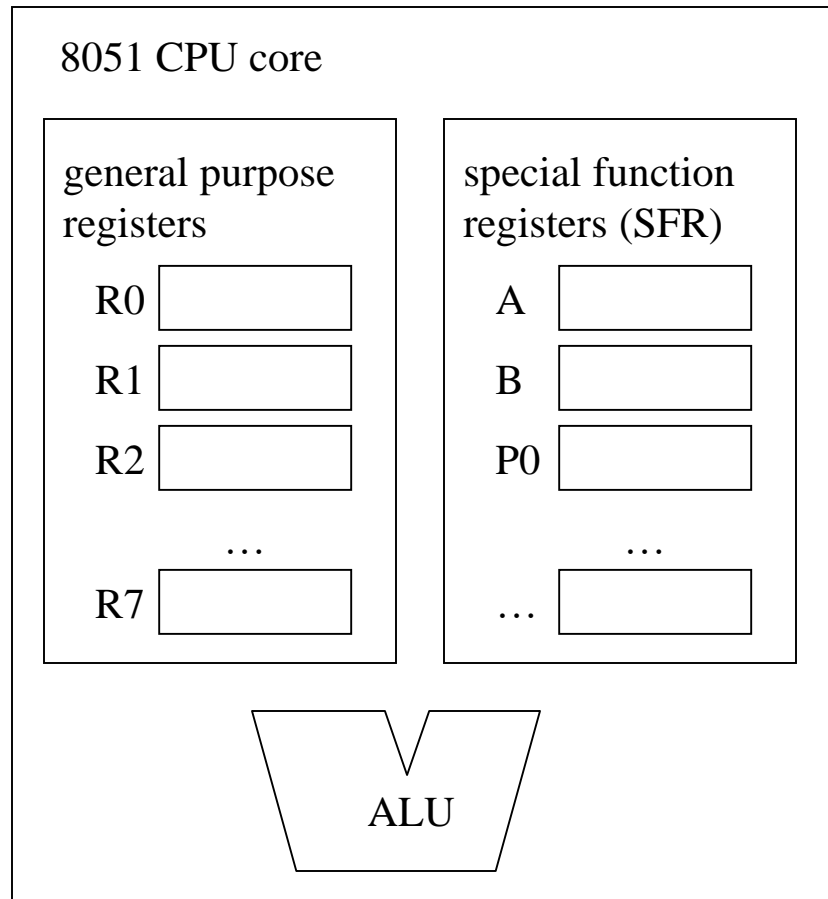

Special Function Registers (SFR)

F8									FF
F0	B								F7
E8									EF
E0	ACC								E7
D8									DF
D0	PSW								D7
C8									CF
C0									C7
B8	IP								BF
B0	P3								B7
A8	IE								AF
A0	P2								A7
98	SCON	SBUF							9F
90	P1								97
88	TCON	TMOD	TL0	TL1	TH0	TH1			8F
80	P0	SP	DPL	DPH				PCON	87

for multiply/divide

accumulator

processor status word

Bit-addressable Registers

A first look on 8051 assembly program





Features of 8051 CPU and assembly

- 8-bit data operation
- two-operand assembly instruction
 - Example: `ADD A, R1` // $A=A+R1$



Classification of instructions

- Arithmetic (ADD, SUBB, MUL, etc.)
 - Notice: the use of register
 - e.g. ADD A, R0
 - e.g. MUL AB
- Branch (AJMP, ACALL, RET)
 - Notice: the jump range
- Data Transfer (MOV)
 - direct/indirect addressing mode
- Logical
 - bit-addressible instruction

8051 assembly language looks like



[label:] mnemonic [operands] [;comment]

```
ORG 0H                ;start (origin) at location 0
    MOV R5,#25H        ;load 25H into R5
    MOV R7,#34H        ;load 34H into R7
    MOV A,#0           ;load 0 into A
    ADD A,R5           ;add contents of R5 to A
                        ;now A = A + R5
    ADD A,R7           ;add contents of R7 to A
                        ;now A = A + R7
    ADD A,#12H         ;add to A value 12H
                        ;now A = A + 12H
HERE: SJMP HERE        ;stay in this loop
    END                ;end of asm source file
```

8051 assembly language looks like

general form

```
[label:] mnemonic [operands] [;comment]
```

```
ORG 0H                ;start (origin) at location 0
    MOV R5,#25H       ;load 25H into R5
    MOV R7,#34H       ;load 34H into R7
    MOV A,#0          ;load 0 into A
    ADD A,R5          ;add contents of R5 to A
                        ;now A = A + R5
    ADD A,R7          ;add contents of R7 to A
                        ;now A = A + R7
    ADD A,#12H        ;add to A value 12H
                        ;now A = A + 12H
HERE: SJMP HERE       ;stay in this loop
    END              ;end of asm source file
```

8051 assembly language looks like

[label:] mnemonic [operands] [;comment]

```
ORG 0H                ;start (origin) at location 0
MOV R5,#25H           ;load 25H into R5
MOV R7,#34H           ;load 34H into R7
MOV A,#0              ;load 0 into A
ADD A,R5              ;add contents of R5 to A
                     ;now A = A + R5
ADD A,R7              ;add contents of R7 to A
                     ;now A = A + R7
ADD A,#12H           ;add to A value 12H
                     ;now A = A + 12H
HERE: SJMP HERE       ;stay in this loop
END                   ;end of asm source file
```

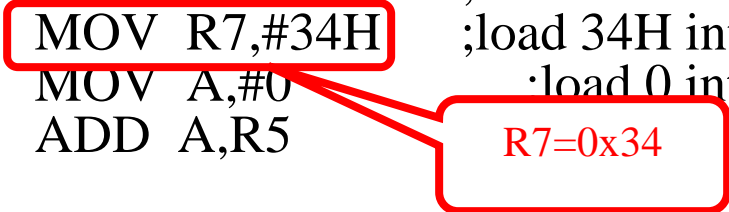

8051 assembly language looks like

[label:] mnemonic [operands] [;comment]

```
ORG 0H                ;start (origin) at location 0
    MOV R5,#25H        ;load 25H into R5
    MOV R7,#34H        ;load 34H into R7
    MOV A,#0           ;load 0 into A
    ADD A,R5           ;add contents of R5 to A
                        ;now A = A + R5
    ADD A,R7           ;add contents of R7 to A
                        ;now A = A + R7
    ADD A,#12H         ;add to A value 12H
                        ;now A = A + 12H
HERE: SJMP HERE        ;stay in this loop
    END                ;end of asm source file
```

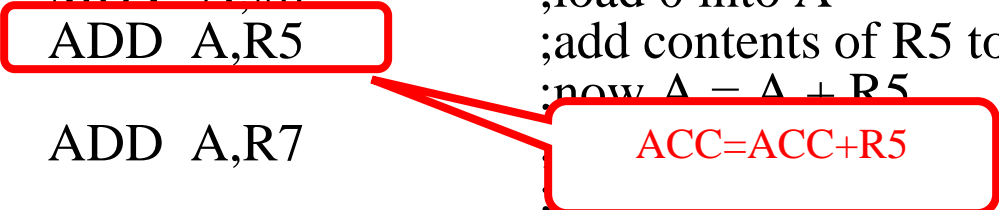

8051 assembly language looks like

[label:] mnemonic [operands] [;comment]

```
ORG 0H                ;start (origin) at location 0
    MOV R5,#25H        ;load 25H into R5
    MOV R7,#34H        ;load 34H into R7
    MOV A,#0           ;load 0 into A
    ADD A,R5           ;add contents of R5 to A
                        ;now A = A + R5
    ADD A,R7           ;add contents of R7 to A
                        ;now A = A + R7
    ADD A,#12H         ;add to A value 12H
                        ;now A = A + 12H
HERE: SJMP HERE        ;stay in this loop
    END                ;end of asm source file
```

goto HERE

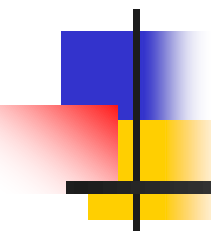

Example 1: $d = a * b + c$



In-Class Exercise

- write the program $d=a*b+c$
 - where a, b, c are originally in the memory
- Hint: 8051 instructions needed
 - add
 - mul (multiplication)
 - inc (increment)
 - mov (move)
- Check the instruction reference manual for **restrictions on using register operands!**

Example: $d = a * b + c$

```
→ mov     R1, #30h   ; R1=30
   mov     A, @R1    ; A=mem[R1]
   inc     R1        ; R1++
   mov     B, @R1    ; B=mem[R1]
   inc     R1        ; R1++
   mov     R0, @R1   ; R0=mem[R1]=C

   mul     AB        ; {A,B} = A*B
   add     A, R0     ; A=A+R0

wait:
   sjmp    wait
```

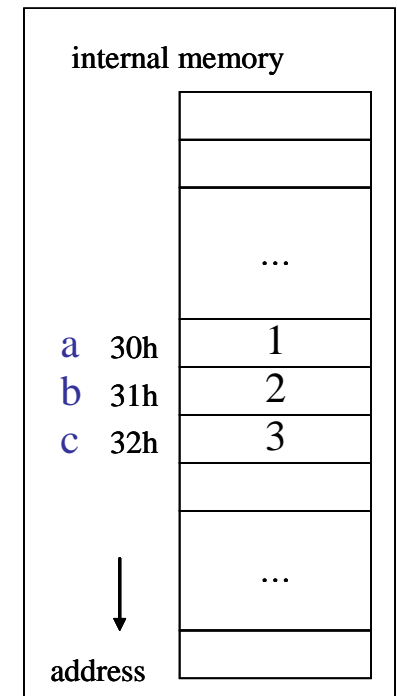
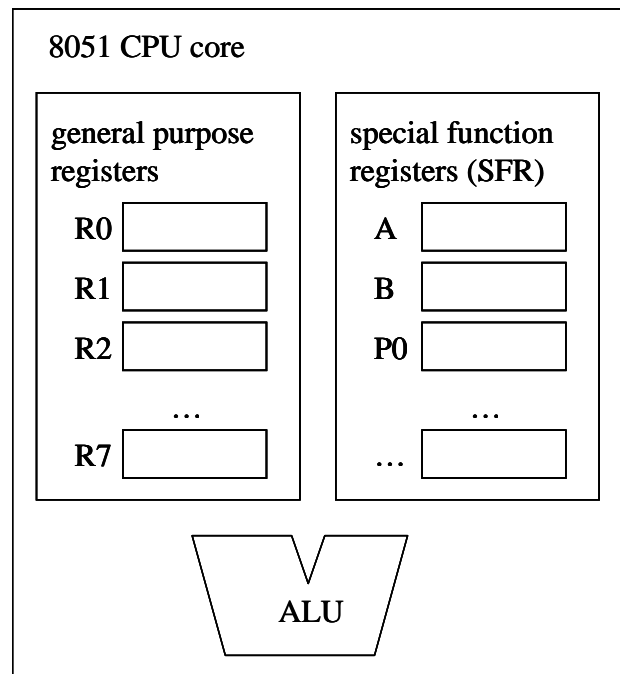

Example: $d = a * b + c$

```
→ mov    R1, #30h    ; R1=30
   mov    A, @R1     ; A=mem[R1]
   inc    R1         ; R1++
   mov    B, @R1     ; B=mem[R1]
   inc    R1         ; R1++
   mov    R0, @R1    ; R0=mem[R1]=C

   mul    AB         ; {A,B} = A*B
   add    A, R0      ; A=A+R0

wait:
   sjmp   wait
```

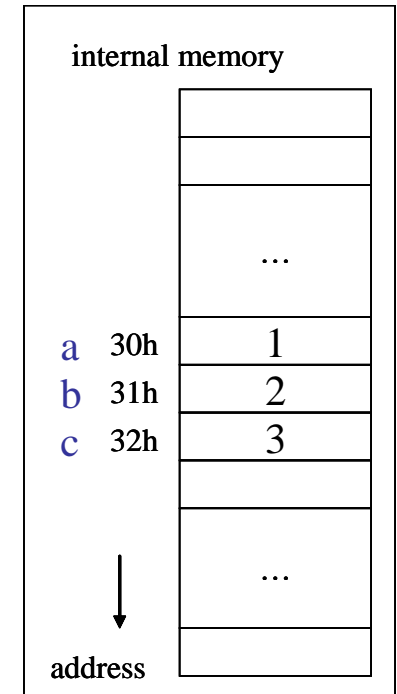
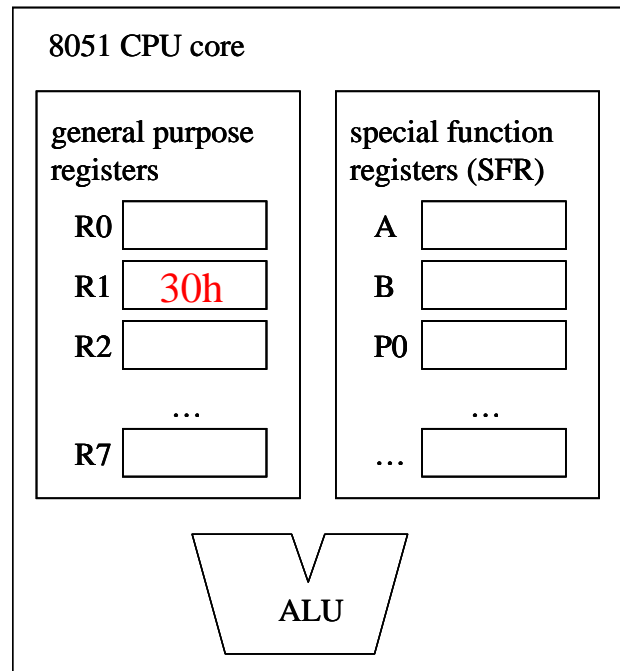

Example: $d = a * b + c$

```
→ mov     R1, #30h   ; R1=30
   mov     A, @R1    ; A=mem[R1]
   inc     R1        ; R1++
   mov     B, @R1    ; B=mem[R1]
   inc     R1        ; R1++
   mov     R0, @R1   ; R0=mem[R1]=C

   mul     AB        ; {A,B} = A*B
   add     A, R0     ; A=A+R0

wait:
   sjmp    wait
```

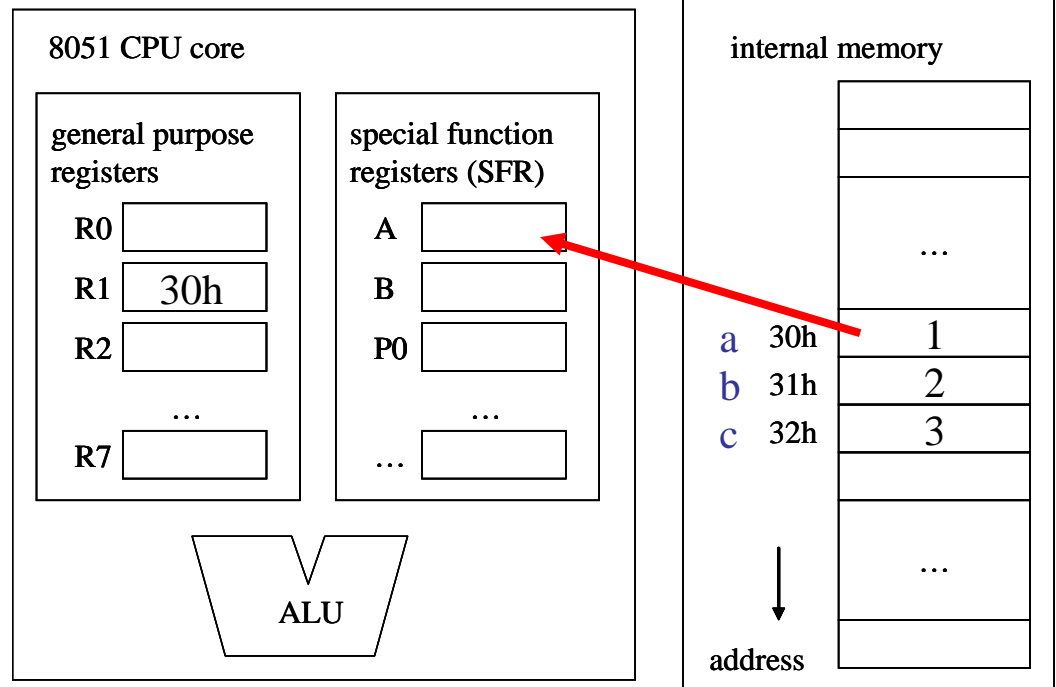

Example: $d = a * b + c$

```
→ mov     R1, #30h   ; R1=30
   mov     A, @R1    ; A=mem[R1]
   inc     R1        ; R1++
   mov     B, @R1    ; B=mem[R1]
   inc     R1        ; R1++
   mov     R0, @R1   ; R0=mem[R1]=C

   mul     AB        ; {A,B} = A*B
   add     A, R0     ; A=A+R0

wait:
   sjmp    wait
```

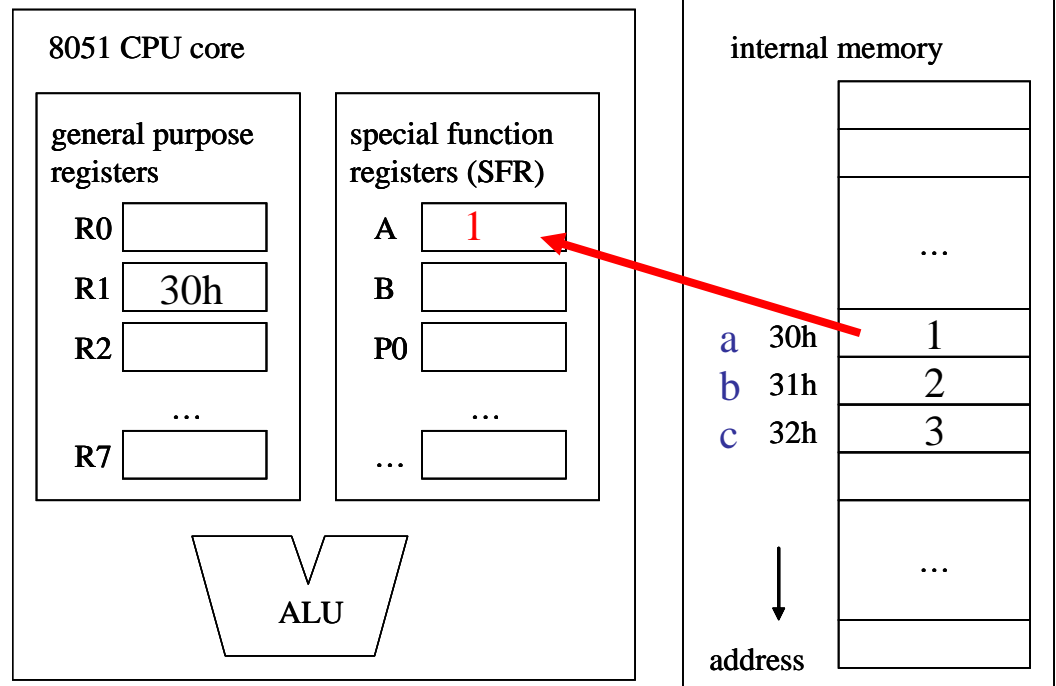

Example: $d = a * b + c$

```
mov    R1, #30h    ; R1=30
mov    A, @R1      ; A=mem[R1]
inc    R1          ; R1++
mov    B, @R1      ; B=mem[R1]
inc    R1          ; R1++
mov    R0, @R1     ; R0=mem[R1]=C
```

```
mul    AB          ; {A,B} = A*B
add    A, R0       ; A=A+R0
```

```
wait:  sjmp        wait
```

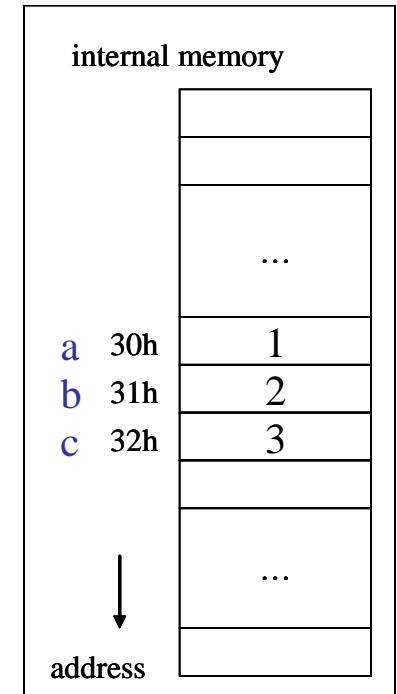
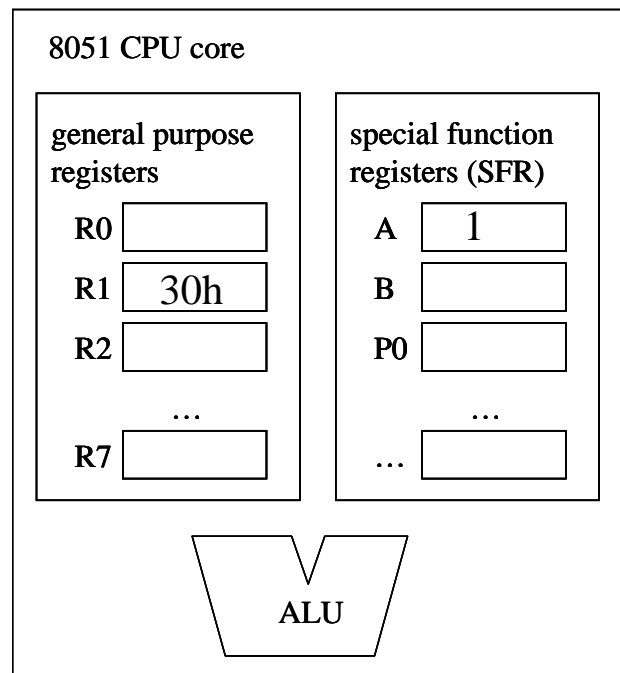

Example: $d = a * b + c$

```
mov    R1, #30h    ; R1=30
mov    A, @R1      ; A=mem[R1]
inc    R1          ; R1++
mov    B, @R1      ; B=mem[R1]
inc    R1          ; R1++
mov    R0, @R1     ; R0=mem[R1]=C
```

```
mul    AB          ; {A,B} = A*B
add    A, R0       ; A=A+R0
```

```
wait:
sjmp  wait
```

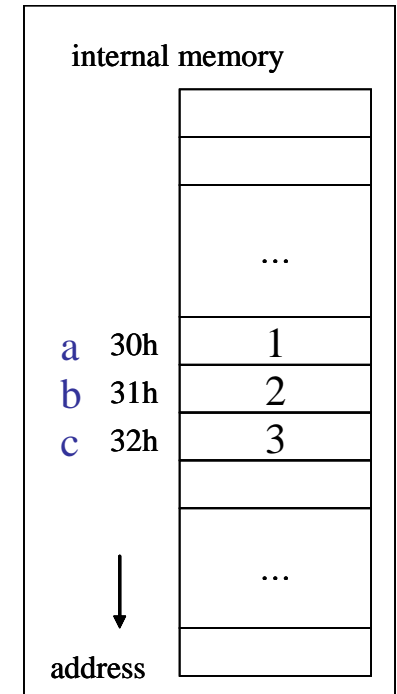
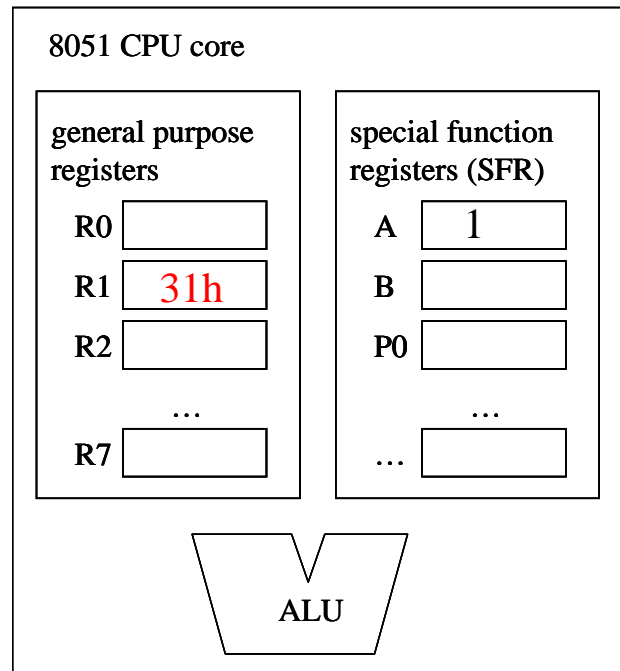

Example: $d = a * b + c$

```
mov    R1, #30h    ; R1=30
mov    A, @R1      ; A=mem[R1]
inc    R1          ; R1++
→ mov    B, @R1     ; B=mem[R1]
inc    R1          ; R1++
mov    R0, @R1     ; R0=mem[R1]=C
```

```
mul    AB          ; {A,B} = A*B
add    A, R0       ; A=A+R0
```

```
wait:
sjmp  wait
```

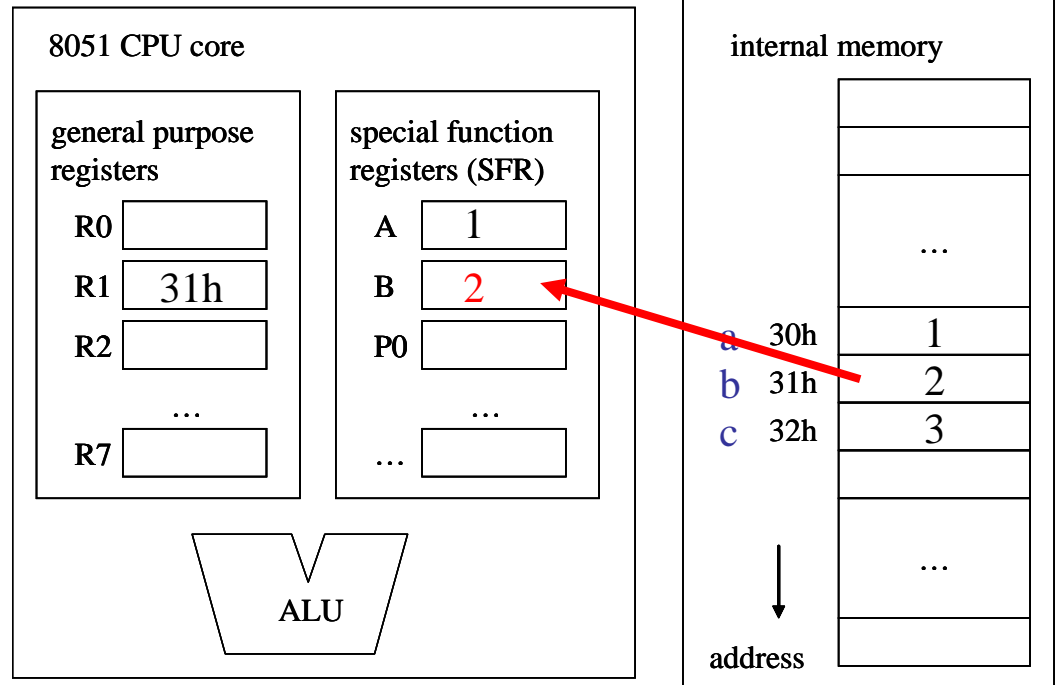

Example: $d = a * b + c$

```
mov    R1, #30h    ; R1=30
mov    A, @R1      ; A=mem[R1]
inc    R1          ; R1++
mov    B, @R1      ; B=mem[R1]
→ inc    R1          ; R1++
mov    R0, @R1     ; R0=mem[R1]=C
```

```
mul    AB          ; {A,B} = A*B
add    A, R0       ; A=A+R0
```

```
wait:
sjmp   wait
```

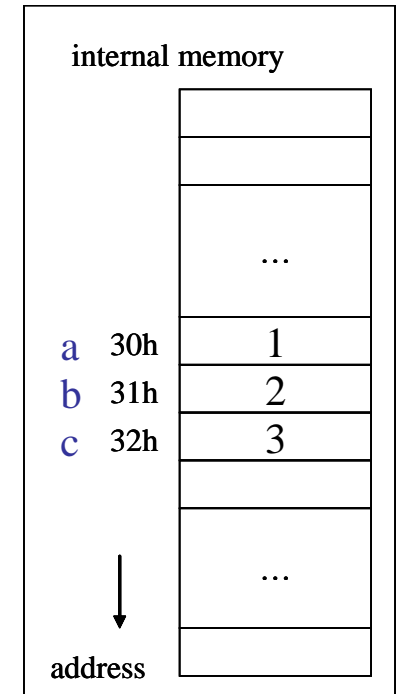
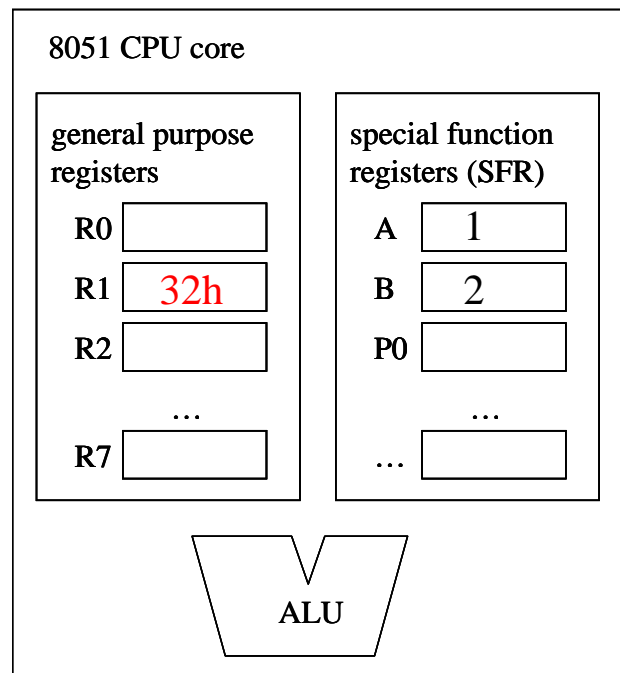

Example: $d = a * b + c$

```
mov    R1, #30h    ; R1=30
mov    A, @R1      ; A=mem[R1]
inc    R1          ; R1++
mov    B, @R1      ; B=mem[R1]
inc    R1          ; R1++
→ mov  R0, @R1     ; R0=mem[R1]=C
```

```
mul    AB          ; {A,B} = A*B
add    A, R0       ; A=A+R0
```

```
wait:
sjmp  wait
```

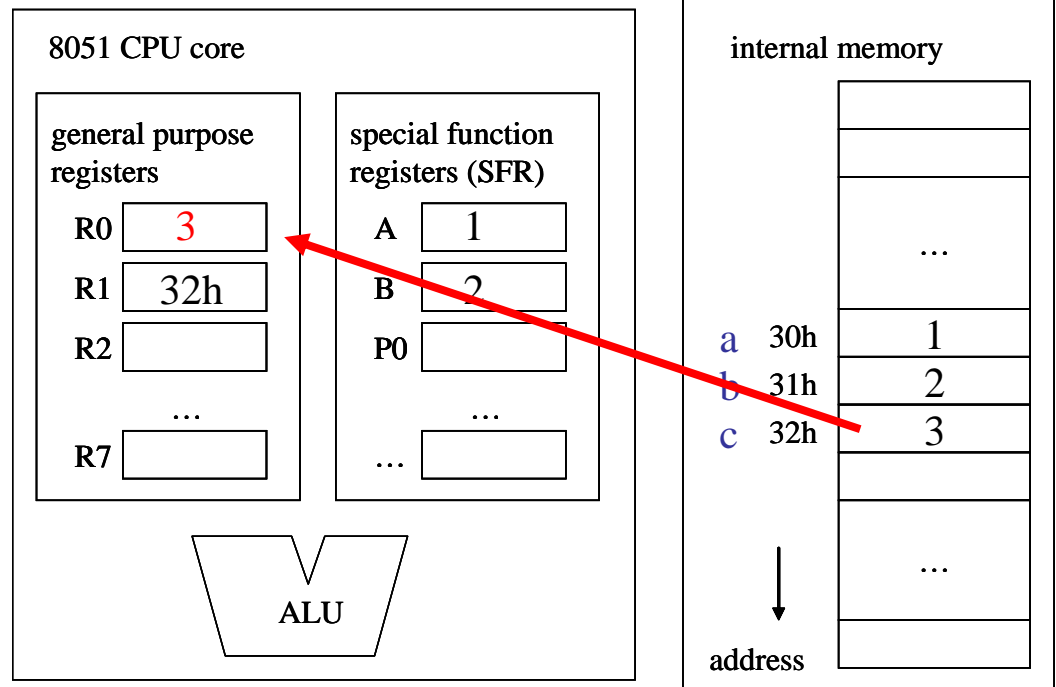

Example: $d = a * b + c$

```
mov    R1, #30h    ; R1=30
mov    A, @R1      ; A=mem[R1]
inc    R1          ; R1++
mov    B, @R1      ; B=mem[R1]
inc    R1          ; R1++
mov    R0, @R1     ; R0=mem[R1]=C
```



```
mul    AB          ; {A,B} = A*B
add    A, R0       ; A=A+R0
```

wait:

```
sjmp   wait
```

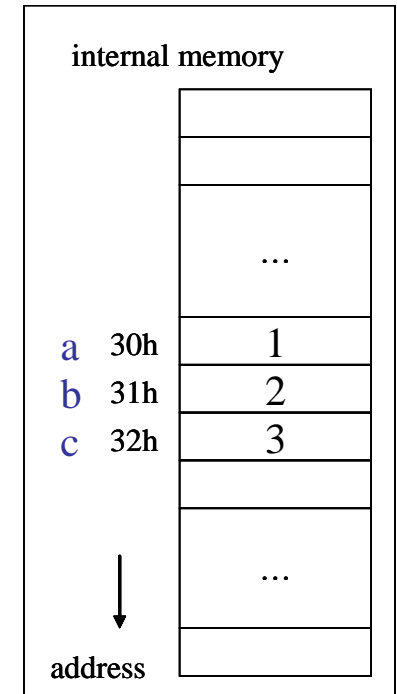
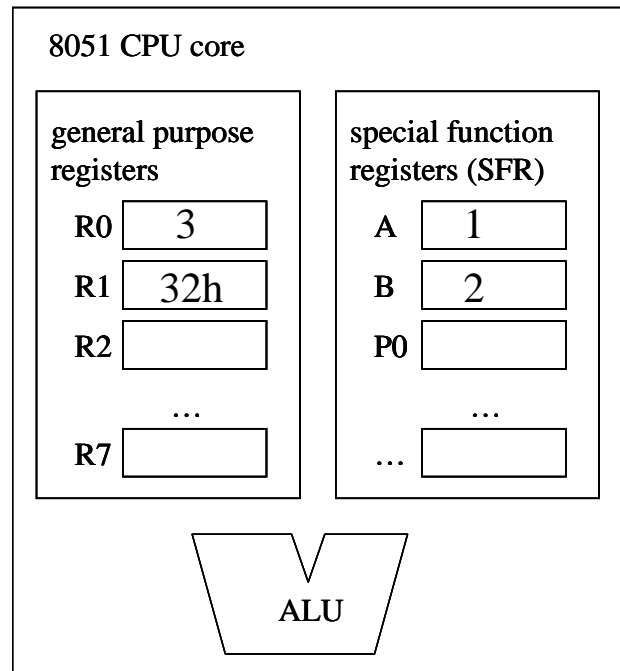

Example: $d = a * b + c$

```
mov    R1, #30h    ; R1=30
mov    A, @R1      ; A=mem[R1]
inc    R1          ; R1++
mov    B, @R1      ; B=mem[R1]
inc    R1          ; R1++
mov    R0, @R1     ; R0=mem[R1]=C
```

```
mul    AB          ; {A,B} = A*B
add    A, R0       ; A=A+R0
```

wait:
sjmp wait

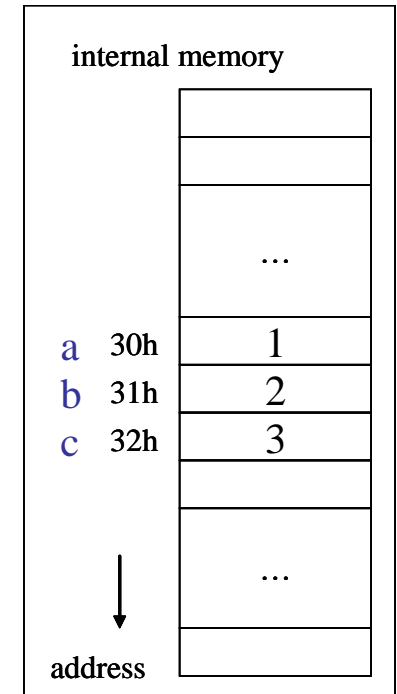
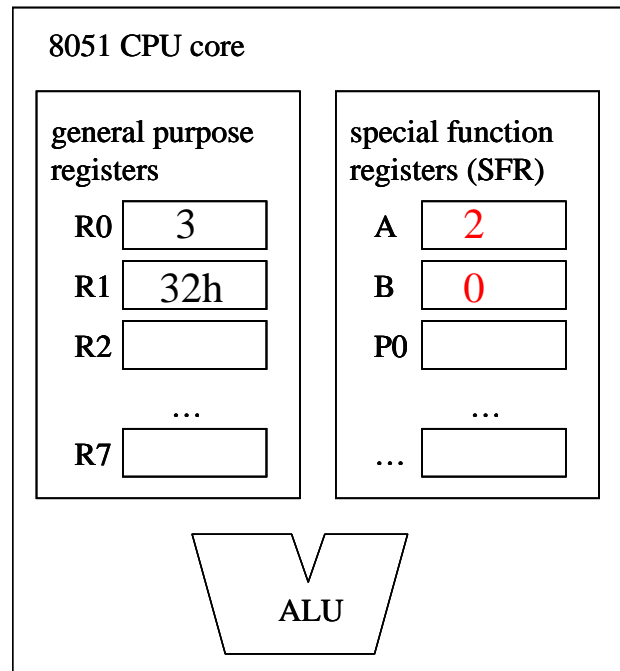

Example: $d = a * b + c$

```
mov    R1, #30h    ; R1=30
mov    A, @R1      ; A=mem[R1]
inc    R1          ; R1++
mov    B, @R1      ; B=mem[R1]
inc    R1          ; R1++
mov    R0, @R1     ; R0=mem[R1]=C
```

```
mul    AB          ; {A,B} = A*B
add    A, R0       ; A=A+R0
```

wait:
sjmp wait

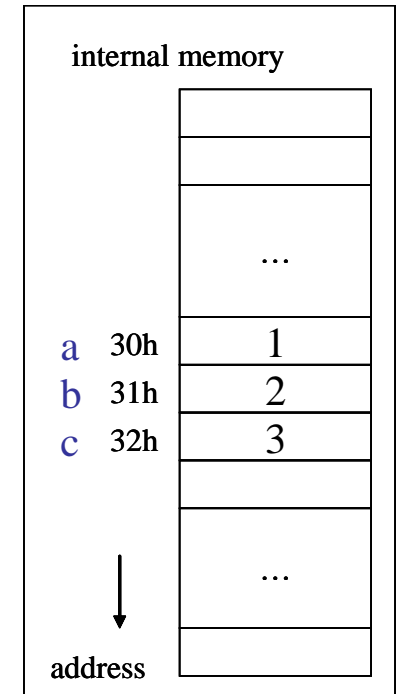
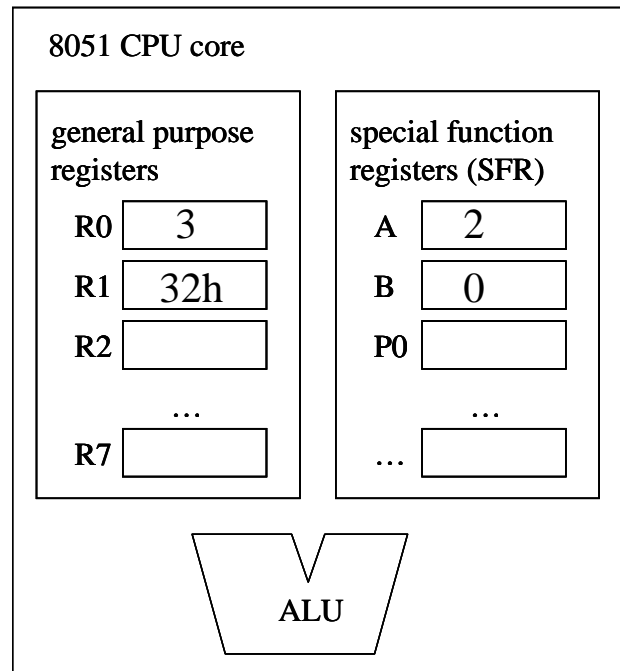

Example: $d = a * b + c$

```
mov    R1, #30h    ; R1=30
mov    A, @R1      ; A=mem[R1]
inc    R1          ; R1++
mov    B, @R1      ; B=mem[R1]
inc    R1          ; R1++
mov    R0, @R1     ; R0=mem[R1]=C
```

```
mul    AB          ; {A,B} = A*B
add    A, R0       ; A=A+R0
```

wait:
sjmp wait

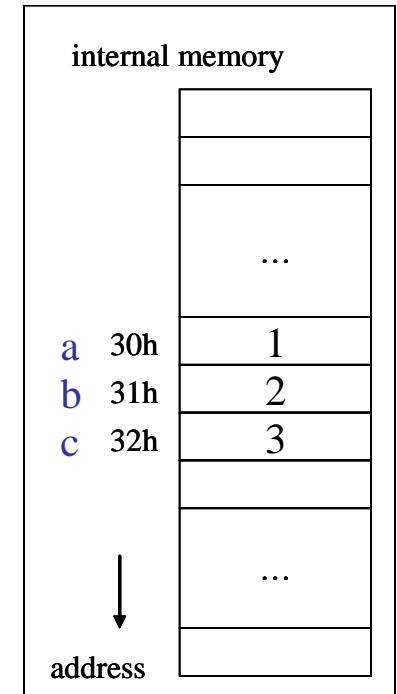
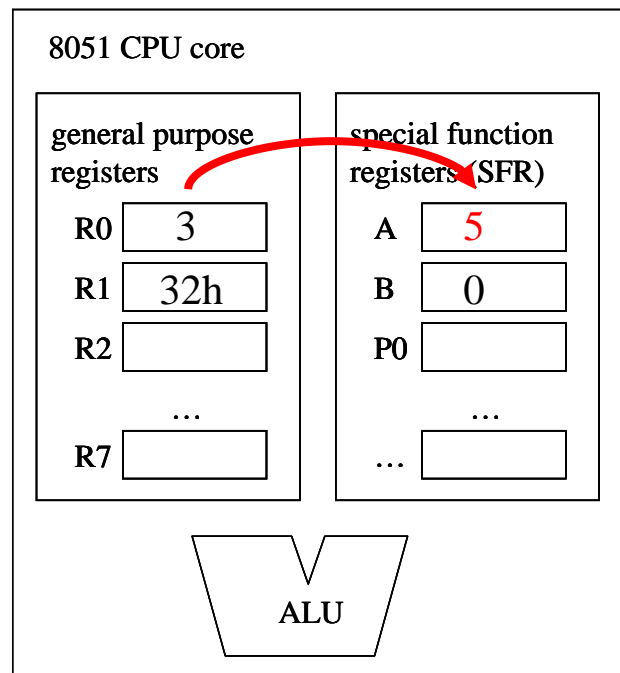



Branch (Jump) Instruction

What is a branch/jump instruction

- the “goto” to control program execution path

the mul instruction
won't be executed

```
add A, R1  
sjmp label_1; goto label_1  
mul AB
```

...

```
label_1:  
add A, R2
```

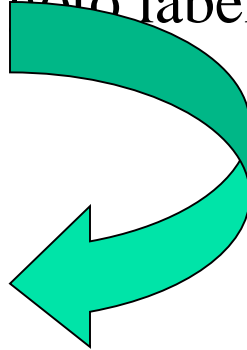

Frequently used branch instructions of 8051

LJMP addr16	Long jump	3	4
SJMP rel	Short jump (from -128 to +127 locations relative to the following instruction)	2	3
JC rel	Jump if carry flag is set. Short jump.	2	3
JNC rel	Jump if carry flag is not set. Short jump.	2	3
JB bit,rel	Jump if direct bit is set. Short jump.	3	4
JBC bit,rel	Jump if direct bit is set and clears bit. Short jump.	3	4
JMP @A+DPTR	Jump indirect relative to the DPTR	1	2
JZ rel	Jump if the accumulator is zero. Short jump.	2	3
JNZ rel	Jump if the accumulator is not zero. Short jump.	2	3

for more, check <http://www.mikroe.com/en/books/8051book/ch3/>



Conditional Branch Instructions

- JC: Jump if Carry=1
- JNC: Jump if Carry=0
- JZ: Jump if A=0
- JNZ: Jump if A!=0
- DJNZ Rn, location
 - $R_n = R_{n-1}$
 - jump if $R_n \neq 0$

How conditional branch works in 8051?



- an arithmetic instruction sets bits in **PSW**
- the conditional branch checks bits in PSW to determine whether to jump or not

How conditional branch works in 8051?

- an arithmetic instruction sets bits in **PSW**
- the conditional branch checks bits in PSW to determine whether to jump or not

a register in SFR

F8									FF
F0	B								F7
E8									E7
E0	ACC								D7
D8									CF
D0	PSW								C7
C8									BF
C0									B7
B8	IP								AF
B0	P3								A7
A8	IE								9F
A0	P2								97
98	SCON	SBUF							8F
90	P1								87
88	TCON	TMOD	TL0	TL1	TH0	TH1			
80	P0	SP	DPL	DPH				PCON	

↑ Bit-addressable Registers

How conditional branch works in 8051?

- an arithmetic instruction sets bits in **PSW**
- the conditional branch checks bits in **PSW** to determine whether to jump or not

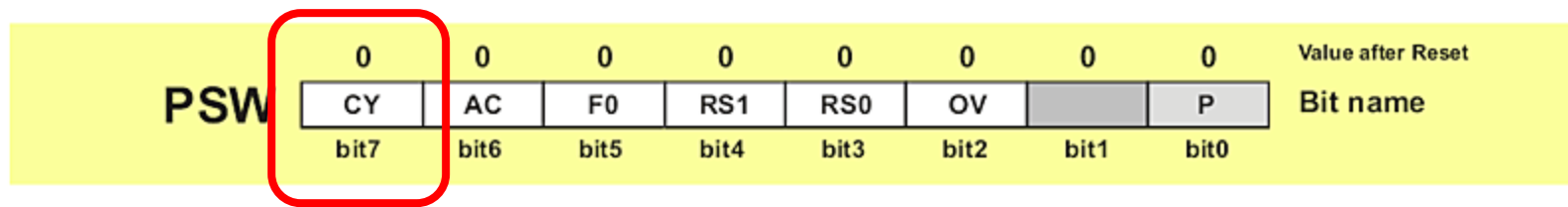

carry flag set by ALU

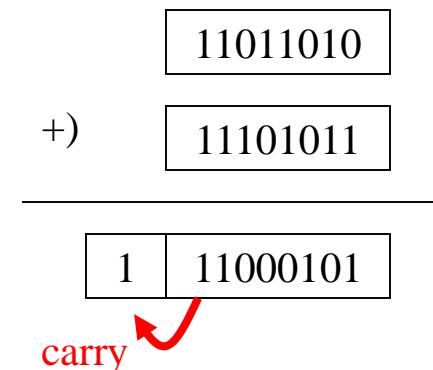
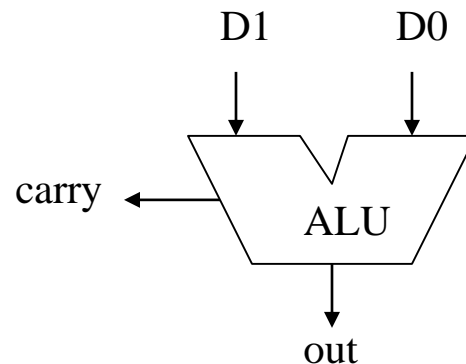



Example of conditional branch instruction

- *JC label*
 - *if (C==1) goto label*
- *JNC label*
 - *if (C==0) goto label*



In-Class Exercise

- write the program:

```
if (R0+R1>0xff)
    A = 0xff;
else
    A = R0+R1
```

Example: using JNC

```
if (R0+R1>0xff)
  A = 0xff;
else
  A = R0+R1
```



```
A = R0;
A = A+R1; //implicitly set C
if (C==0) goto exit;
A = 0xff;
exit:
...
```



```
mov   A, R0
add   A, R1
JNC   exit
mov   A, #ffh
exit:
...
```



Example: a simple for loop



A useful instruction

- DJNZ Rn, location
 - $R_n = R_{n-1}$
 - jump if $R_n \neq 0$



Loop example

```
sum = 0;
for (i=10;i>0;i--)
    sum = sum+i;
```



```
A = 0;    //A is sum
R0 = 10;  //R0 is i

loop_start:
A = A+R0;
if (--R0) goto loop_start;
```



```
mov    A, #0
mov    R0, #10

loop_start:
add    A, R0
djnz   R0, loop_start
```

Now you should be able to do your work



- write a program to compute

$$S = \sum_{i=0}^{N-1} A[i] * B[i]$$

- where $A[i]$, $B[i]$ are integer array (8-bit) in 8051's internal memory
- instructions you may use:
 - ADD (addition)
 - MUL (multiply)
 - MOV (move data)
 - DJNZ (decrement and jump if not zero)
- Check the instruction reference manual!



Lab01 Study Report

- File name: Bxxxxxxx-MCE-Lab1-Study
- File type: PDF only
- The requirements of report
 - Summarize the content of this slide set
 - Provide your plan for this lab exercise
 - No more than one A4 page
 - Grading: 80 ± 15
- Deadline: 2021/10/13 23:00 (不收遲交)
- Upload to e-learning system



Lab01 Lab Exercise Report

- File name: Bxxxxxxx-MCE-Lab1-Result
- File type: PDF only
- The requirements of report
 - Summarize the problems and results you have in this exercise
 - Some screen shots or some code explanation can be provided
 - No more than two A4 pages
 - Grading: 80 ± 15
- Deadline: 2021/10/20 23:00 (不收遲交)
- Upload to e-learning system